

UD3300

2010 Model Year



WHEELBASES	E	H	K	M	R
GVWR (lb.) †	32,900	32,900	32,900	32,900	32,900
Chassis Weight (lb.) ‡	10,205	10,400	10,510	10,620	10,840
Front (lb.)	6,310	6,375	6,440	6,485	6,615
Rear (lb.)	3,895	4,025	4,070	4,135	4,225
Gross Payload (lb.)*	22,695	22,500	22,390	22,280	22,060
Wheelbase (in.) ** WB	150.39	177.17	192.91	208.66	238.19
Cab-to-Rear Axle (in.) CA	118.27	145.04	160.79	176.54	206.06
Rear Overhang (in.) RO	44.88	72.83	76.97	88.58	110.24
Overall Length (in.) OL	245.67	300.39	320.28	347.64	398.82
Turning Radius (ft.)	21.30	25.40	27.40	29.40	32.80
Typical Body Lengths (ft.)***	14/16	16/18	18/20	20/22	24/26

† GVWR on automatic transmission, refuse application, is 24,200 lbs. ‡ Chassis Weight will be 35 lbs. heavier at the "Rear", on average, when Air-Ride suspension is selected. *Gross payload capacity equals GVWR minus chassis weight. Installation of specialized equipment or bodies may require frame reinforcement. **Wheelbase selection should be based on specific weight distribution. ***Typical body lengths assume water level load (no specific consideration for driver, passengers, or fuel) to maximize GVWR. Addition of ancillary equipment such as lift gates and refrigeration units not considered in calculations.

ENGINE	MD-230* 24 Valve
	Turbo/Intercooled Diesel
	In-line 6 cylinder, Direct-injection
Horsepower	230 hp @ 2,500 rpm
Torque	506 lb. ft. @ 1,500 rpm
Displacement	469 in. ³ (7.684 L)
Cylinder Liner	Dry, replaceable
Air Compressor	20.8 CFM @ 2,600 engine rpm (nominal)
Fuel System	Electronically controlled common rail system
Air Cleaner	11 in., paper filter type (DONALDSON)
Cold Starting Aid	Automatic electric glow plug
Fan	Viscous type drive

*MD-230 (J08E-UJ) is a vendor engine manufactured for Nissan Diesel Motor Company

FRONT AXLE

GAWR	11,900 lb.
Rated Axle Capacity	11,900 lb.
Axle Type	"I" Beam
Suspension	Semi-elliptic leaf springs
Shock Absorbers	Telescopic type



Transmission	STD	OPTION
	Nissan Diesel, MLS63B	Allison, 2500RDS
	Manual, 6 forward speeds & 1 reverse	Automatic
	synchronesh on 2nd through 6th gears	5 forward speeds & 1 reverse

Ratios

1st	6.72	3.51
2nd	4.03	1.90
3rd	2.30	1.44
4th	1.44	1.00
5th	1.00	0.74
6th	0.74	—
Rev.	6.12	5.09
R/A Ratio	5.57 5.86std 6.83	5.57 5.86std 6.17 6.83
Engine rpm @ 65 mph	2,250 2,365 2,760	2,245* 2,360* NEED INFO

*Approximate engine rpm only. Allison will provide a performance scan by application on request.

CLUTCH	Hydraulic clutch with air assist
	13.8 in. cerametallic friction material
	Standard clutch wear indicator

STEERING	Integral power steering, gear driven pump
----------	---

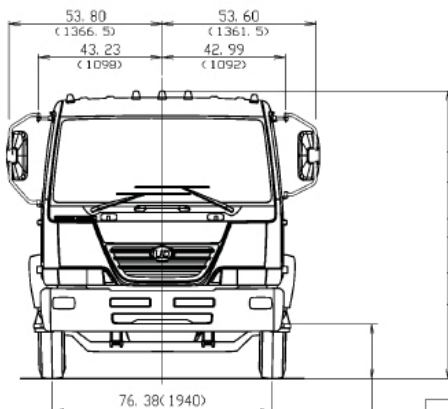

MODEL	FIRST STEP HEIGHT
UD3300E	20.67 (525)

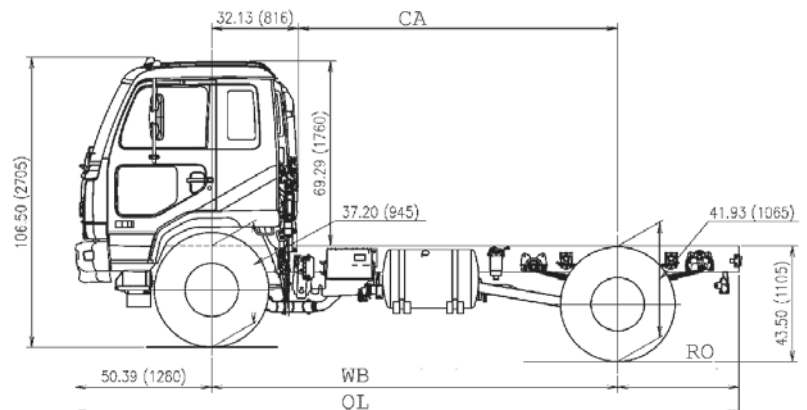

UD3300

2010 Model Year



REAR AXLE

GAWR	21,000 lb.
Rated Axle Capacity	21,000 lb.
Axle Type	Full-floating banjo housing
Suspension Type	Semi-elliptic leaf springs with auxiliary springs

WHEELS & TIRES

Tires	Front: Single, highway tread Rear: Dual, highway tread 11R22.5 - 14PR (tubeless radial)
Wheels	Steel disc type, 10 hole, 22.5 x 8.25 in., offset 6.50 in.

BRAKE SYSTEM

Service Brakes	Anti-lock Braking System "S" cam air brake system with automatic slack adjusters
Front	Drum diameter x lining width x lining thickness: 16.14 x 5.91 x 0.63 in.
Rear	Drum diameter x lining width x lining thickness: 16.14 x 8.66 x 0.63 in.
Air Tanks	Supply: 1,831 in. ³ Front service: 732 in. ³ Rear service: 1,086 in. ³ Total: 3,637 in. ³
Air Dryer	Standard
Parking Brake	Pneumatically controlled spring brakes, operated by push/pull button, acting on rear wheels

EXHAUST BRAKE

Electrically controlled, pneumatically activated butterfly valve in exhaust pipe

CHASSIS FRAME

Ladder type, channel section side rails

Dimensions (in.)*	9.84 x 3.15 x 0.31
Assembled width (in.)	33.86
Section Modulus (in. ³)**	35.7 (with reinforcement) 26.6 (W/B -E only, without reinforcement)
Yield Strength (psi)	51,200
RBM (in.-lb.)	1,828,000 1,362,000 W/B -E

*Height x Flange Width x Thickness

**Measured at back-of-cab, specifications based on complete chassis (both rails)

FUEL TANK

Round fuel tank, mounted to left side
Capacity - 50 gallons

CAB

Air Conditioner	Standard
Cab Glass	Windshield, tinted laminated, 2,314 in. ²
Cruise Control	Standard
Door Vent Window	Driver, ventilating type
Driver's Seat	Height & seat back angle adjustable w/air suspension, cloth cover, high back type
Floormat	Standard
Keyless Entry	Standard
Passenger Seat	Seat back angle adjustable. Cloth cover, high back
Power Windows & Door Locks	Standard
Seat Belts	Driver & passenger, 3-point ELR type
Rearview Mirrors	West coast type, 6.5 x 11 in. with Convex type, 5.8 x 4.3 in.
Steering Column	Tilt & telescopic type
Sun Visors	Driver & passenger
Windshield Wipers	Intermittent & 2 speed

ELECTRICAL EQUIPMENT

Back-up lights
Cigar lighter
Clearance, identification & position lights
Day-time running lights
Halogen headlights, 2 lamps
Interior and map light
License light
Side turn signal lights
Stop/tail lights
Turn signal/hazard lights
Power outlet - 12 volt

INSTRUMENTS

Meters & Gauges
Air pressure gauges
Coolant temperature gauge
Fuel gauge
Speedometer, odometer & trip meter
Tachometer

Warning & Indicator

Lights & Buzzers
ABS warning light
Alternator low charge warning light
Automatic Transmission:
- Check warning light
- Range inhibited warning light
- High temperature fluid warning light & buzzer
Cab lock warning light & buzzer
Engine control system warning light
Engine glow plug indicator light
Exhaust brake indicator light
External air restriction indicator
Hazard warning flasher
High beam indicator light
Low air pressure warning light & buzzer
Low coolant level & overheating warning light & buzzer
Low oil pressure warning light
Parking brake indicator light
Sedimentor warning light
Service brake warning light & buzzer
Turn signal indicator lights
Warning lights with burnt-out bulb check function
Backup alarm
DPF warning/indicator lights

OTHER OPTIONS

90 Gallon aluminum fuel tank
AM/FM stereo radio with CD
Air-Ride Suspension
Block heater
Center console/third seat
Heated mirrors
Rear traction tires
90 Gallon aluminum fuel tank

All illustrations, specifications and descriptions in this specification are based on the latest product information available at the time of this publication. The right is reserved to make changes in price, materials, equipment, design, specifications, diagrams and models, and to discontinue models of equipment at any time, without notice and without incurring any obligation whatsoever. For more information on additional options and accessories, contact NISSAN DIESEL AMERICA, INC.

Manufacturer:
NISSAN DIESEL MOTOR CO., LTD.
Saitama, Japan

Distributor:
NISSAN DIESEL AMERICA, INC.
P.O. Box 152034
Irving, Texas 75015-2034
www.udtrucks.com